

LL 系列

Ratings for LL Series

105°C 2000 - 10000小时    2000 - 10000h at 105°C

- 105°C 长寿命
- Longest Lifetime 105°C
- 低阻抗
- Low Impedance
- 适用于电源类产品
- Power Supplies

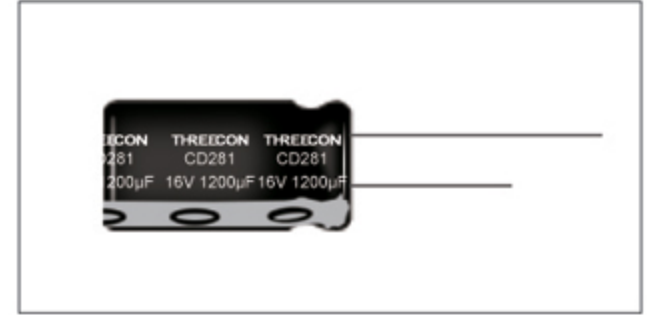

项目 Item	特性 Characteristics																		
使用温度范围(°C) Operating Temperature Range	-40~+105																		
额定电压范围(V) Voltage Range	6.3~100																		
标称电容量范围(µF) Capacitance Range	4.7~15000																		
标称电容量允许偏差) Capacitance Tolerance(20°C, 120Hz)	± 20%																		
漏电流(µA) Leakage Current	$I \leq 0.02CV$ 或 $3 \mu A$ , 取较大者 (20°C, 2分钟) $I \leq 0.02CV$ or $3 \mu A$ whichever is greater (at 20°C, after 2 minutes) C: 标称电容量 (µF) V: 额定电压 (V)    C: Nominal Capacitance (µF) V: Rated Voltage (V)																		
损耗角正切值 (tg δ) Dissipation Factor(20°C, 120Hz)	<table border="1"> <tr> <td>额定电压 Rated Voltage (V)</td> <td>6.3</td> <td>10</td> <td>16</td> <td>25</td> <td>35</td> <td>50</td> <td>63</td> <td>100</td> </tr> <tr> <td>损耗角正切值 Tan δ(max)</td> <td>0.22</td> <td>0.19</td> <td>0.16</td> <td>0.14</td> <td>0.12</td> <td>0.10</td> <td>0.09</td> <td>0.08</td> </tr> </table> <p>标称电容量大于1000µF者, 每增加1000µF, 其损耗角正切值增加0.02 For Capacitances &gt; 1000µF add 0.02 to every 1000µF</p>	额定电压 Rated Voltage (V)	6.3	10	16	25	35	50	63	100	损耗角正切值 Tan δ(max)	0.22	0.19	0.16	0.14	0.12	0.10	0.09	0.08
额定电压 Rated Voltage (V)	6.3	10	16	25	35	50	63	100											
损耗角正切值 Tan δ(max)	0.22	0.19	0.16	0.14	0.12	0.10	0.09	0.08											
低温特性 Stability at Low Temperature (Impedance Ratio at 120Hz)	<table border="1"> <tr> <td>额定电压 Rated Voltage(V)</td> <td>6.3~100</td> </tr> <tr> <td>Z-40°C / Z +20°C</td> <td>3</td> </tr> </table>	额定电压 Rated Voltage(V)	6.3~100	Z-40°C / Z +20°C	3														
额定电压 Rated Voltage(V)	6.3~100																		
Z-40°C / Z +20°C	3																		

项目 Item	使用寿命 Useful Life		负载寿命 Load Life	耐久试验 Endurance Test	高温贮存 shelf Life
寿命 Lifetime	ΦD=5 : 4000h ΦD=6.3-8 : 6000h ΦD=10 : 10000h ΦD=12.5~18: 12000h	ΦD≥ 6.3:>250000h	ΦD=5 : 2000h ΦD=6.3-8 : 4000h ΦD=10 : 8000h ΦD=12.5~18: 10000h	ΦD=5 : 3000h ΦD=6.3-8 : 5000h ΦD=10 : 8000h ΦD=12.5~18: 10000h	1000h
漏电流 Leakage Current	≤ 初始规定值 Not more than specified value		≤ 初始规定值 Not more than specified value	≤ 初始规定值 Not more than specified value	≤ 初始规定值 Not more than specified value
容量变化率 Capacitance Change	初始值 ± 30% 以内 Within ±30% of initial Value		初始值 ± 20% 以内 Within ±20% of initial Value	初始值 ± 20% 以内 Within ±20% of initial Value	初始值 ± 20% 以内 Within ±20% of initial Value
损耗变化率 Dissipation Factor	≤ 初始规定值的3倍 Not more than 300% of specified value		≤ 初始规定值的2倍 Not more than 200% of specified value	≤ 初始规定值的2倍 Not more than 200% of specified value	≤ 初始规定值的2倍 Not more than 200% of specified value
使用条件 Condition: 使用电压 APPLIED Voltage 使用电流 Applied Current 使用温度 APPLIED Temperature	Ur Ir 105°C	Ur 1.4×Ir 40°C	Ur Ir 105°C	Ur Ir=0 105°C	Ur=0 Ir=0 105°C <div style="border: 1px solid black; padding: 5px; width: fit-content;">试验后: 施加额定电压30分钟 后恢复24小时 After test: Ur to be applied for 30min &gt;24h before measurement</div>



CD 281 系列  
Ratings for CD 281 Series

U <sub>R</sub> (Surge Voltage) Code	Rated Capacitance	Max ESR 20°C 120HZ	Max Imp 20°C 100KHZ	Max Imp -10°C 100KHZ	Rated Ripple Current 105°C 100KHZ	Size Φ DXL
(V)	(μF)	(Ω)	(Ω)	(Ω)	(mAmps)	(mm)
6.3 (7.2) 0J	100	2.919	0.65	1.3	175	5×11.5
	150	1.946	0.46	0.92	235	5×15
	220	1.327	0.3	0.6	290	6.3×11.5
	330	0.885	0.2	0.4	400	6.3×15
	470	0.621	0.17	0.34	488	8×11.5
	680	0.429	0.13	0.26	617	8×16
		0.429	0.12	0.24	613	10×12.5
	820	0.356	0.095	0.19	734	10×16
	1000	0.292	0.095	0.19	800	8×20
	1200	0.243	0.065	0.13	1010	10×20
		0.243	0.065	0.13	1010	12.5×15
	1500	0.195	0.055	0.11	1190	10×25
	2200	0.145	0.045	0.09	1440	10×30
		0.145	0.042	0.084	1400	12.5×20
	2700	0.118	0.038	0.076	1690	12.5×25
		0.118	0.046	0.092	1310	16×15
	3300	0.105	0.043	0.086	1460	18×15
	3900	0.088	0.032	0.064	1950	12.5×30
	4700	0.079	0.028	0.056	2220	12.5×35
		0.079	0.034	0.068	1660	16×20
5600	0.071	0.026	0.052	2390	12.5×40	
	0.071	0.028	0.056	2070	16×25	
	0.071	0.03	0.06	1850	18×20	
6800	0.062	0.025	0.05	2350	16×31.5	
	0.062	0.027	0.054	2120	18×25	
8200	0.058	0.022	0.044	2550	16×35.5	
10000	0.053	0.023	0.046	2410	18×31.5	
12000	0.049	0.02	0.04	2970	16×40	
	0.049	0.02	0.04	2680	18×35.5	
15000	0.044	0.019	0.038	3010	18×40	
10 (13) 1A	82	3.075	0.65	1.3	175	5×11.5
	100	2.521	0.46	0.92	235	5×15
	180	1.401	0.3	0.6	290	6.3×11.5
	220	1.146	0.2	0.4	400	6.3×15
	330	0.764	0.17	0.34	488	8×11.5
	470	0.536	0.13	0.26	617	8×16
		0.536	0.12	0.24	613	10×12.5
	560	0.45	0.095	0.19	734	10×16
	680	0.371	0.095	0.19	800	8×20
	1000	0.252	0.065	0.13	1010	10×20
		0.252	0.065	0.13	1010	12.5×15
	1200	0.21	0.055	0.11	1190	10×25
	1500	0.168	0.045	0.09	1440	10×30
	1800	0.14	0.042	0.084	1400	12.5×20
		0.14	0.046	0.092	1310	16×15
	2200	0.127	0.038	0.076	1690	12.5×25
		0.127	0.043	0.086	1460	18×15
	2700	0.103	0.032	0.064	1950	12.5×30
	3300	0.092	0.028	0.056	2220	12.5×35
		0.092	0.034	0.068	1660	16×20
3900	0.078	0.026	0.052	2390	12.5×40	
	0.078	0.028	0.056	2070	16×25	
	0.078	0.03	0.06	1850	18×20	
4700	0.071	0.027	0.054	2120	18×25	
5600	0.064	0.025	0.05	2350	16×31.5	
6800	0.057	0.022	0.044	2550	16×35.5	
	0.057	0.023	0.046	2410	18×31.5	

U <sub>R</sub> (Surge Voltage) Code	Rated Capacitance	Max ESR 20°C 120HZ	Max Imp 20°C 100KHZ	Max Imp -10°C 100KHZ	Rated Ripple Current 105°C 100KHZ	Size Φ DXL
(V)	(μF)	(Ω)	(Ω)	(Ω)	(mAmps)	(mm)
10 (13) 1A	8200	0.053	0.02	0.04	2970	16×40
		0.053	0.02	0.04	2680	18×35.5
16 (20) 1C	10000	0.049	0.019	0.038	3010	18×40
	56	3.791	0.65	1.3	175	5×11.5
	82	2.589	0.46	0.92	235	5×15
	120	1.769	0.3	0.6	290	6.3×11.5
	180	1.180	0.2	0.4	400	6.3×15
	270	0.786	0.17	0.34	501	8×11.5
	330	0.643	0.13	0.26	575	8×16
		0.643	0.12	0.24	625	10×12.5
	390	0.544	0.095	0.19	795	10×16
	470	0.452	0.095	0.19	760	8×20
	680	0.312	0.065	0.13	1010	10×20
		0.312	0.065	0.13	1010	12.5×15
	820	0.259	0.055	0.11	1190	10×25
	1200	0.177	0.045	0.09	1430	10×30
		0.177	0.042	0.084	1400	12.5×20
	1500	0.142	0.038	0.076	1690	12.5×25
		0.142	0.046	0.092	1340	16×15
	2200	0.142	0.043	0.086	1490	18×15
		0.109	0.032	0.064	1950	12.5×30
	2700	0.109	0.034	0.068	1730	16×20
0.088		0.028	0.056	2200	12.5×35	
3300	0.088	0.028	0.056	2070	16×25	
	0.088	0.03	0.06	1870	18×20	
3900	0.08	0.026	0.052	2390	12.5×40	
4700	0.068	0.025	0.05	2350	16×31.5	
	0.068	0.027	0.054	2160	18×25	
5600	0.062	0.022	0.044	2550	16×35.5	
	0.062	0.023	0.046	2450	18×31.5	
6800	0.057	0.02	0.04	2900	16×40	
8200	0.049	0.019	0.038	3060	18×40	
25 (32) 1E	39	4.763	0.65	1.3	175	5×11.5
	56	3.317	0.46	0.92	235	5×15
	82	2.266	0.3	0.6	290	6.3×11.5
	120	1.548	0.2	0.4	400	6.3×15
	180	1.032	0.17	0.34	503	8×11.5
	220	0.844	0.13	0.26	575	8×16
		0.844	0.12	0.24	629	10×12.5
	270	0.688	0.095	0.19	795	10×16
	330	0.563	0.095	0.19	751	8×20
	470	0.395	0.065	0.13	1010	10×20
		0.395	0.065	0.13	1010	12.5×15
	560	0.332	0.055	0.11	1190	10×25
	820	0.227	0.045	0.09	1440	10×30
		0.227	0.042	0.084	1400	12.5×20
	1000	0.227	0.046	0.092	1360	16×15
		0.186	0.038	0.076	1690	12.5×25
	1200	0.155	0.043	0.086	1500	18×15
	1500	0.124	0.032	0.064	1950	12.5×30
		0.124	0.034	0.068	1730	16×20
	1800	0.103	0.028	0.056	2200	12.5×35
0.103		0.028	0.056	2070	16×25	
2200	0.103	0.03	0.06	1890	18×20	
	0.097	0.026	0.052	2390	12.5×40	
2700	0.079	0.025	0.05	2350	16×31.5	

外形图尺寸表 Dimensions

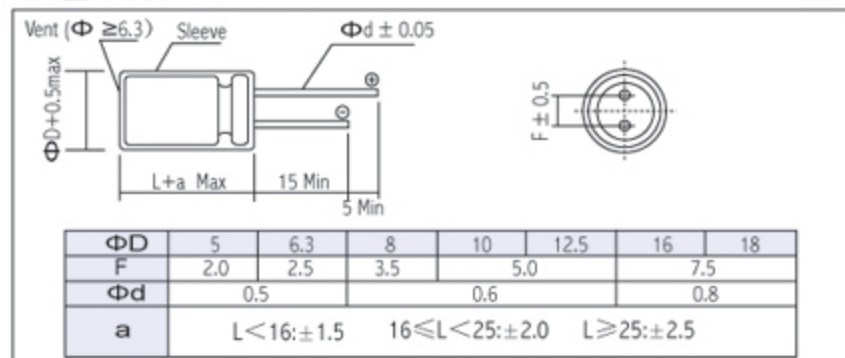

频率系数 Frequency Coefficient

Frequency 容量 Cap(μF)	120Hz	1KHz	10KHz	100KHz
4.7	0.40	0.68	0.78	1.00
5.6~47	0.50	0.76	0.87	1.00
56~270	0.70	0.85	0.90	1.00
330~1000	0.80	0.93	0.98	1.00
1200~15000	0.90	0.95	1.00	1.00



CD 281 系列  
Ratings for CD 281 Series

U <sub>R</sub> (Surge Voltage) Code	Rated Capa- citan- ce	Max ESR 20°C 120HZ	Max Imp 20°C 100KHZ	Max Imp -10°C 100KHZ	Rated Ripple Current 105°C 100KHZ	Size Φ DXL	
(V)	(μF)	(Ω)	(Ω)	(Ω)	(mA <sub>rms</sub> )	(mm)	
25 (32) 1E	2700	0.079	0.027	0.054	2180	18×25	
	3300	0.072	0.022	0.044	2550	16×35.5	
		0.072	0.023	0.046	2470	18×31.5	
	3900	0.061	0.02	0.04	2900	16×40	
		0.061	0.02	0.04	2740	18×35.5	
4700	0.056	0.019	0.038	3070	18×40		
35 (44) 1V	27	5.898	0.65	1.3	175	5×11.5	
	39	4.083	0.46	0.92	235	5×15	
	56	2.843	0.3	0.6	290	6.3×11.5	
	82	1.942	0.2	0.4	400	6.3×15	
	120	1.327	0.17	0.34	501	8×11.5	
	150	1.062	0.12	0.24	625	10×12.5	
	180	0.885	0.13	0.26	575	8×16	
		0.885	0.095	0.19	795	10×16	
	220	0.724	0.095	0.19	760	8×20	
	330	0.483	0.065	0.13	1010	10×20	
		0.483	0.065	0.13	1010	12.5×15	
	390	0.408	0.055	0.11	1190	10×25	
	560	0.284	0.045	0.09	1450	10×30	
		0.284	0.042	0.084	1400	12.5×20	
	680	0.284	0.046	0.092	1360	16×15	
		0.234	0.038	0.076	1690	12.5×25	
	1000	0.234	0.043	0.086	1520	18×15	
		0.159	0.032	0.064	1950	12.5×30	
	1200	0.159	0.034	0.068	1730	16×20	
		0.133	0.028	0.056	2200	12.5×35	
	1500	0.133	0.028	0.056	2070	16×25	
		0.133	0.03	0.06	1900	18×20	
	1800	0.106	0.026	0.52	2390	12.5×40	
	2200	0.088	0.025	0.05	2350	16×31.5	
		0.088	0.027	0.054	2200	18×25	
	2700	0.084	0.022	0.044	2550	16×35.5	
		0.084	0.023	0.046	2490	18×31.5	
	3300	0.069	0.02	0.04	2900	16×40	
		0.069	0.02	0.04	2770	18×31.5	
	3900	0.064	0.019	0.038	3110	18×40	
	50 (63) 1H	4.7	28.233	2.2	4.4	75	5×11.5
		10	13.270	1.4	2.8	110	5×11.5
		18	7.372	0.95	1.9	120	5×11.5
		27	4.915	0.55	1.1	135	5×15
		39	3.402	0.36	0.72	148	6.3×11.5
56		2.370	0.28	0.56	153	6.3×15	
68		1.951	0.20	0.40	360	8×11.5	
82		1.618	0.18	0.36	460	8×16	
		1.618	0.18	0.36	443	10×12.5	
100		1.327	0.15	0.3	553	10×16	
120		1.106	0.13	0.26	670	8×20	
180		0.737	0.085	0.17	676	10×20	
		0.737	0.095	0.19	745	12.5×15	
220		0.603	0.075	0.15	876	10×25	
330		0.402	0.055	0.11	1010	10×30	
		0.402	0.060	0.12	979	12.5×20	
470		0.402	0.065	0.13	982	16×15	
		0.282	0.044	0.088	1180	12.5×25	
560		0.282	0.048	0.096	1180	18×15	
		0.237	0.040	0.080	1310	12.5×30	
680	0.195	0.036	0.072	1470	12.5×35		
	0.195	0.045	0.090	1210	16×20		
820	0.162	0.034	0.068	1590	12.5×40		
	0.162	0.038	0.076	1490	16×25		
1000	0.162	0.036	0.072	1450	18×20		
	0.133	0.032	0.064	1890	16×31.5		
1200	0.133	0.032	0.064	1720	18×25		
1500	0.111	0.028	0.056	2140	16×35.5		
	0.088	0.026	0.052	2410	16×40		
1800	0.088	0.026	0.052	1970	18×31.5		
	0.074	0.025	0.050	2310	18×35.5		

U <sub>R</sub> (Surge Voltage) Code	Rated Capa- citan- ce	Max ESR 20°C 120HZ	Max Imp 20°C 100KHZ	Max Imp -10°C 100KHZ	Rated Ripple Current 105°C 100KHZ	Size Φ DXL
(V)	(μF)	(Ω)	(Ω)	(Ω)	(mA <sub>rms</sub> )	(mm)
63 (79) 1J	2200	0.072	0.024	0.048	2530	18×40
	12	9.952	1.2	3.6	120	5×11.5
	18	6.635	0.85	2.6	135	5×15
	27	4.423	0.55	1.7	148	6.3×11.5
	39	3.062	0.38	1.1	153	6.3×15
	47	2.541	0.32	0.96	360	8×11.5
	56	2.133	0.23	0.69	448	10×12.5
	68	1.756	0.24	0.72	469	8×16
		1.756	0.17	0.51	553	10×16
	82	1.456	0.17	0.51	682	8×20
	120	0.995	0.12	0.36	676	10×20
	150	0.796	0.10	0.30	876	10×25
		0.796	0.11	0.33	745	12.5×15
	180	0.663	0.085	0.26	1020	10×30
	220	0.543	0.075	0.23	979	12.5×20
		0.543	0.080	0.24	928	16×15
	270	0.442	0.065	0.20	1180	12.5×25
	330	0.362	0.065	0.20	1200	18×15
	390	0.306	0.055	0.17	1310	12.5×30
		0.306	0.057	0.17	1210	16×20
	470	0.254	0.048	0.14	1470	12.5×35
		0.254	0.052	0.16	1490	16×25
	560	0.254	0.058	0.17	1460	18×20
		0.213	0.042	0.13	1590	12.5×40
	680	0.176	0.042	0.13	1890	16×31.5
	820	0.176	0.050	0.15	1740	18×25
		0.146	0.036	0.11	2140	16×35.5
1000	0.146	0.042	0.13	1990	18×31.5	
	0.119	0.032	0.096	2410	16×40	
1200	0.119	0.035	0.11	2340	18×35.5	
	0.100	0.032	0.096	2560	18×40	
100 (125) 2A	5.6	18.957	1.9	7.6	57	5×11.5
	8.2	12.946	1.3	5.2	74	5×15
	12	8.846	1.1	4.4	78	6.3×11.5
	18	5.898	0.62	2.5	85	6.3×15
	22	4.825	0.53	2.1	275	8×11.5
	27	3.932	0.47	1.9	319	10×12.5
	33	3.217	0.35	1.4	360	8×16
		3.217	0.32	1.3	424	10×16
	39	2.722	0.27	1.1	490	8×20
	56	1.896	0.25	1.0	499	10×20
	68	1.561	0.18	0.72	634	10×25
		1.561	0.20	0.80	613	12.5×15
	100	1.062	0.15	0.60	739	10×30
		1.062	0.13	0.52	805	12.5×20
	120	0.885	0.11	0.44	857	12.5×25
		0.885	0.13	0.5	706	16×15
	150	0.708	0.12	0.48	871	18×15
	180	0.59	0.09	0.36	1120	12.5×30
		0.59	0.11	0.44	916	16×20
	220	0.483	0.075	0.3	1240	12.5×35
0.483		0.081	0.32	1290	16×25	
270	0.393	0.06	0.24	1330	12.5×40	
	0.393	0.085	0.34	1170	18×20	
330	0.322	0.059	0.23	1630	16×31.5	
	0.322	0.071	0.28	1500	18×25	
390	0.272	0.052	0.21	1750	16×35.5	
	0.272	0.058	0.23	1630	18×31.5	
470	0.226	0.045	0.18	1920	16×40	
560	0.19	0.054	0.22	1920	18×35.5	
680	0.156	0.041	0.16	2100	18×40	

RADIAL