



KC系列

Ratings for KC Series

105°C 3000小时

- 耐高温长寿命
- 高纹波
- 专业电源类产品

3000h at 105°C

- Long Life at High Temperature
- High Ripple Current
- Professional Power Supplies



项目 Item	特性 Characteristics							
使用温度范围(°C) Operating Temperature Range	-40~+105				-25~+105			
额定电压范围(V) Voltage Range	16~100				160~500			
标称电容量范围(μF) Capacitance Range	47~47000							
标称电容量允许偏差 Capacitance Tolerance(20°C,120Hz)	± 20%							
漏电流(μA) Leakage Current	I ≤ 0.01CV 或 1.5mA, 取较小者 (20°C,5分钟) I ≤ 0.01CV or 1.5mA whichever is smaller (at 20°C,after 5 minutes) C: 标称电容量 (μF) V: 额定电压 (V) C: Nominal Capacitance (μF) V: Rated Voltage (V)							
损耗角正切值 (tg δ) Dissipation Factor(20°C,120Hz)	额定电压 Rated Voltage (V)	16	25	35	50	63~100	160~400	450~500
	损耗角正切值 Tan δ (max)	0.50	0.40	0.35	0.30	0.20	0.15	0.20
低温特性 Stability at Low Temperature (Impedance Ratio at 120Hz)	额定电压 Rated Voltage(V)	16~100		160~200		250~500		
	Z _{-25°C} / Z _{+20°C}	4						
	Z _{-40°C} / Z _{+20°C}	15		—				

项目 Item	使用寿命 Useful Life		负载寿命 Load Life	耐久试验 Endurance Test	高温贮存 shelf Life
寿命 Lifetime	5000h	>200000h	3000h	3000h	1000h
漏电流 Leakage Current	≤ 初始规定值 Not more than specified value		≤ 初始规定值 Not more than specified value	≤ 初始规定值 Not more than specified value	≤ 初始规定值 Not more than specified value
容量变化率 Capacitance Change	初始值 ± 30%以内 Within ± 30% of initial Value		初始值 ± 20%以内 Within ± 20% of initial Value	初始值 ± 20%以内 Within ± 20% of initial Value	初始值 ± 20%以内 Within ± 20% of initial Value
损耗变化率 Dissipation Factor	≤ 初始规定值的3倍 Not more than 300% of specified value		≤ 初始规定值的2倍 Not more than 200% of specified value	≤ 初始规定值的2倍 Not more than 200% of specified value	≤ 初始规定值的2倍 Not more than 200% of specified value
使用条件 Condition: 使用电压 APPLIED Voltage 使用电流 Applied Current 使用温度 APPLIED Temperature	U _R	U _R	U _R	U _R	U _R =0
	I _R	1.4×I _R	I _R	I _R =0	I _R =0
	105°C	40°C	105°C	105°C	105°C
	试验后: 施加额定电压30分 钟后恢复24小时 After test: U _R to be applied for 30min >24h before measurement				

CD 296 系列
Ratings for CD 296 Series

U _R (Surge Voltage) Code (V)	Rated Capacitance (μF)	Max ESR 20°C 120HZ (mΩ)	Typ ESR 20°C 120HZ (mΩ)	Rated Ripple Current 105°C120HZ (Arms)	Size Φ DXL (mm)
16 (20) 1C	6800	98	68	1.6	22×25
	8200	81	57	1.8	25×25
	10000	66	46	1.99	22×30
		66	46	1.99	25×25
	12000	55	39	2.28	22×35
		55	39	2.3	25×30
		55	39	2.38	30×25
	15000	44	31	2.64	22×40
		44	31	2.68	25×35
	18000	37	26	2.98	22×45
		37	26	3.04	25×40
		37	26	3	30×30
		37	26	3.1	35×25
	22000	30	21	3.4	25×45
		30	21	3.39	30×35
	27000	25	17	3.81	25×50
		25	17	3.83	30×40
		25	17	3.74	35×30
33000	20	14	4.3	30×45	
	20	14	4.24	35×35	
39000	17	12	4.74	30×50	
	17	12	4.72	35×40	
47000	14	10	5.27	35×45	
25 (32) 1E	4700	113	79	1.55	22×25
	5600	95	66	1.7	25×25
	6800	78	55	1.91	22×30
		78	55	1.91	25×25
	8200	65	45	2.14	22×35
		65	45	2.16	25×30
		65	45	2.25	30×25
	10000	53	37	2.4	22×40
		53	37	2.44	25×35
	12000	44	31	2.69	22×45
		44	31	2.74	25×40
		44	31	2.7	30×30
		44	31	2.8	35×25
	15000	35	25	3.15	25×45
		35	25	3.13	30×35
		35	25	3.22	35×30
	18000	30	21	3.54	25×50
		30	21	3.54	30×40
22000	24	17	4.24	30×45	
	24	17	3.96	35×35	
27000	20	14	4.75	35×45	
33000	16	11	5.39	35×50	
35 (44) 1V	3300	141	99	1.43	22×25
	3900	119	83	1.65	22×30
	4700	99	69	1.78	25×25
	5600	83	58	2.02	22×35
		83	58	2.04	25×30
83	58	2.12	30×25		

U _R (Surge Voltage) Code (V)	Rated Capacitance (μF)	Max ESR 20°C 120HZ (mΩ)	Typ ESR 20°C 120HZ (mΩ)	Rated Ripple Current 105°C120HZ (Arms)	Size Φ DXL (mm)	
35 (44) 1V	6800	68	48	2.28	22×40	
		68	48	2.31	25×35	
	8200	57	40	2.67	22×50	
		57	40	2.6	25×40	
		57	40	2.56	30×30	
		57	40	2.78	35×25	
	10000	46	33	2.92	25×45	
		46	33	2.92	30×35	
	12000	39	27	3.26	25×50	
		39	27	3.28	30×40	
		39	27	3.2	35×30	
		31	22	3.74	30×45	
	15000	31	22	3.69	35×35	
		26	18	4.16	35×40	
	18000	21	15	4.92	35×50	
	22000	21	15	4.92	35×50	
	50 (63) 1H	1800	221	155	1.31	22×25
		2200	181	127	1.45	22×30
2700		147	103	1.7	22×30	
		147	103	1.7	25×25	
3300		121	84	1.98	22×35	
		121	84	2	25×30	
3900		102	72	2.25	22×40	
		102	72	2.28	25×35	
		102	72	2.22	30×25	
4700		85	59	2.56	22×45	
		85	59	2.58	30×30	
		85	59	2.67	35×25	
5600		71	50	2.89	22×50	
		71	50	2.81	25×40	
		71	50	2.95	30×35	
6800		59	41	3.37	25×50	
		59	41	3.39	30×40	
		59	41	3.31	35×30	
8200	49	34	3.71	30×45		
	49	34	3.66	35×35		
	40	28	4.09	30×50		
10000	40	28	4.07	35×40		
	33	23	4.5	35×45		
12000	33	23	4.5	35×45		
	221	155	1.25	22×25		
	177	124	1.39	25×25		
63 (79) 1J	1800	147	103	1.52	22×30	
	147	103	1.52	25×25		

外形图尺寸表 Dimensions mm

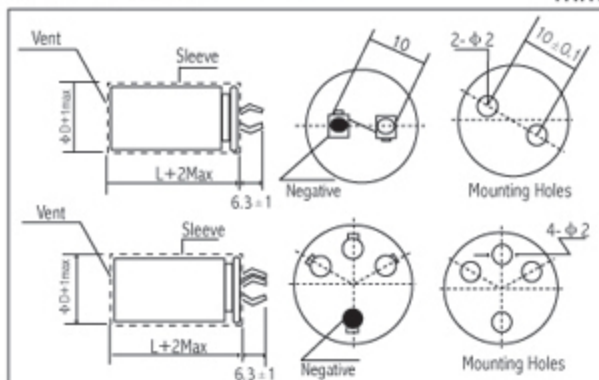

频率系数 Frequency Coefficient

额定电压 Rated voltage(V)	频率 Frequency	50Hz	120Hz	1KHz	10KHz	≥20KHz
≤100		0.95	1.00	1.10	1.15	1.15
160~250		0.87	1.00	1.11	1.18	1.20
≥350		0.80	1.00	1.14	1.14	1.20



CD 296 系列
Ratings for CD 296 Series

U _R (Surge Voltage) Code (V)	Rated Capacitance (μF)	Max ESR 20°C 120HZ (mΩ)	Typ ESR 20°C 120HZ (mΩ)	Rated Ripple Current 105°C120HZ (Arms)	Size Φ DXL (mm)
63 (79) 1J	2200	121	84	1.73	22×35
		121	84	1.75	25×30
	2700	98	69	1.97	22×40
		98	69	1.99	25×35
		98	69	1.93	30×25
	3300	80	56	2.32	22×50
		80	56	2.27	25×40
		80	56	2.24	30×30
		80	56	2.41	35×25
	3900	68	48	2.54	25×45
		68	48	2.55	30×35
	4700	57	40	2.88	25×50
		57	40	2.9	30×40
		57	40	2.83	35×30
	5600	47	33	3.28	30×45
		47	33	3.24	35×35
6800	39	27	3.73	30×50	
	39	27	3.71	35×40	
8200	32	23	4.16	35×45	
10000	27	19	4.69	35×50	
80 (100) 1K	820	324	227	1.11	22×25
		265	186	1.25	22×25
	1200	221	155	1.39	22×30
		221	155	1.39	25×25
	1500	177	124	1.61	22×35
		177	124	1.62	25×30
	1800	147	103	1.83	22×40
		147	103	1.81	30×25
	2200	121	84	2.09	22×45
		121	84	2.01	25×35
		121	84	2.1	30×30
		121	84	2.17	35×25
	2700	98	69	2.43	25×45
		98	69	2.43	30×35
	3300	80	56	2.76	25×50
		80	56	2.78	30×40
80		56	2.71	35×30	
3900	68	48	3.12	30×45	
	68	48	3.07	35×35	
4700	57	40	3.56	30×50	
	57	40	3.5	35×40	
5600	47	33	3.87	35×45	
6800	39	27	4.19	35×50	
100 (125) 2A	560	474	332	1.07	22×25
		324	227	1.35	22×30
	820	324	227	1.35	25×25
		265	186	1.54	22×35
	1000	265	186	1.56	25×30
		221	155	1.74	22×40
	1200	221	155	1.76	25×35
		221	155	1.71	30×25
		177	124	1.99	22×45
	1500	177	124	2.03	25×40
		177	124	2	30×30
		177	124	2.07	35×25
	1800	147	103	2.28	25×45
		147	103	2.27	30×35
	2200	121	84	2.57	25×50
		121	84	2.59	30×40
121		84	2.52	35×30	
2700	98	69	2.94	30×45	
	98	69	2.9	35×35	
3300	80	56	3.32	30×50	
	80	56	3.31	35×40	
3900	68	48	3.69	35×45	
4700	57	40	4.14	35×50	

U _R (Surge Voltage) Code (V)	Rated Capacitance (μF)	Max ESR 20°C 120HZ (mΩ)	Typ ESR 20°C 120HZ (mΩ)	Rated Ripple Current 105°C120HZ (Arms)	Size Φ DXL (mm)
160 (200) 2C	330	603	422	1.16	22×25
		390	510	357	1.43
	470	424	296	1.52	22×35
		424	296	1.55	25×25
	560	355	349	1.62	22×40
		355	349	1.73	25×30
	680	293	205	1.7	22×45
		293	205	1.81	25×35
		293	205	1.82	30×25
	820	243	170	1.81	22×50
		243	170	1.98	25×40
		243	170	1.98	30×30
	1000	243	170	1.93	35×25
		199	139	2.04	25×45
		199	139	2.14	30×35
	1200	166	116	2.12	25×50
166		116	2.22	30×40	
166		116	2.4	35×30	
1500	133	93	2.46	30×45	
	133	93	2.53	35×35	
1800	111	77	2.98	35×45	
180 (225) 2K	270	737	516	1.08	22×25
		330	603	422	1.3
	390	510	357	1.35	25×25
		424	296	1.5	22×35
	470	424	296	1.62	25×30
		355	249	1.62	22×40
	560	355	249	1.69	25×35
		355	249	1.67	30×25
		293	205	1.76	22×50
	680	293	205	1.72	25×40
		293	205	1.74	30×30
		293	205	1.92	35×25
	820	243	170	1.78	25×45
		243	170	1.85	30×35
	1000	199	139	1.91	25×50
		199	139	2.01	30×40
199		139	2.16	35×30	
1200	166	116	2.19	30×45	
	166	116	2.34	35×35	
1500	133	93	2.36	30×50	
	133	93	2.56	35×40	
1800	111	77	2.67	35×45	
200 (250) 2D	220	905	633	1.08	22×25
		330	603	422	1.3
	390	603	422	1.35	25×25
		510	357	1.41	22×35
	470	424	296	1.5	22×40
		424	296	1.47	25×30
		424	296	1.56	30×25
	560	355	249	1.58	22×45
		355	249	1.65	25×35
	680	293	205	1.68	22×50
		293	205	1.8	25×40
		293	205	1.82	30×30
	820	293	205	1.96	35×25
		243	170	1.87	25×50
		243	170	1.99	30×35
	1000	243	170	2.07	35×30
199		139	2.17	30×45	
199		139	2.22	35×35	
1200	166	116	2.32	30×50	
	166	116	2.42	35×40	
1500	133	93	2.59	35×45	
1800	111	77	2.7	35×50	

SNAP-IN/LUG

CD 296 系列

Ratings for CD 296 Series

U _R (Surge Voltage) Code (V)	Rated Capacitance (μF)	Max ESR 20°C 120HZ (mΩ)	Typ ESR 20°C 120HZ (mΩ)	Rated Ripple Current 105°C120HZ (Arms)	Size Φ DXL (mm)
250 (300) 2E	180	1106	744	0.94	22×25
	220	905	633	1.1	22×30
		905	633	1.15	25×25
	270	737	516	1.13	22×35
	330	603	422	1.2	22×40
		603	422	1.3	25×30
		603	422	1.3	30×25
	390	510	357	1.41	22×45
		510	357	1.42	25×35
	470	424	296	1.48	22×50
		424	296	1.47	25×40
		424	296	1.51	30×30
	560	424	296	1.5	35×25
		355	249	1.59	25×45
		355	249	1.57	30×35
	680	355	249	1.56	35×30
		293	205	1.66	25×50
		293	205	1.68	30×40
	820	243	170	1.83	30×45
		243	170	1.82	35×35
1000	199	139	1.87	30×50	
	199	139	1.99	35×40	
1200	166	116	2.1	35×45	
350 (400) 2V	68	2927	1610	0.56	22×25
	100	1990	1095	0.7	22×30
		1990	1095	0.7	25×25
	120	1659	912	0.73	22×35
	150	1327	730	0.79	22×40
		1327	730	0.82	25×30
		1327	730	0.82	30×25
	180	1106	608	0.81	22×45
		1106	608	0.89	25×35
		1106	608	0.9	30×30
	220	905	498	0.93	22×50
		905	498	0.97	25×40
		905	498	0.98	35×25
	270	737	406	1.01	25×50
		737	406	1.05	30×35
		737	406	1.01	35×30
	330	603	332	1.16	30×45
		603	332	1.16	35×35
	390	510	281	1.26	30×50
		510	281	1.26	35×40
470	424	233	1.35	35×45	
560	355	196	1.51	35×50	
400 (450) 2G	68	2927	1522	0.47	22×25
	82	2427	1262	0.56	22×30
		2427	1262	0.56	25×25
	100	1990	1035	0.62	22×30
	120	1659	863	0.66	22×35
		1659	863	0.68	25×30
		1659	863	0.7	30×25
	150	1327	690	0.73	22×40
		1327	690	0.73	25×35
	180	1106	575	0.78	22×50
		1106	575	0.82	25×40
		1106	575	0.83	30×30
		1106	575	0.86	35×25
	220	905	471	0.87	25×45
		905	471	0.96	30×35
		737	383	0.94	25×50
	270	737	383	0.95	30×40
		737	383	0.91	35×30
		603	314	1.11	30×45
	330	603	314	1.13	35×35
510		265	1.15	30×50	

U _R (Surge Voltage) Code (V)	Rated Capacitance (μF)	Max ESR 20°C 120HZ (mΩ)	Typ ESR 20°C 120HZ (mΩ)	Rated Ripple Current 105°C120HZ (Arms)	Size Φ DXL (mm)
400 (450) 2G	390	510	265	1.26	35×40
	470	424	220	1.31	35×45
		560	355	185	1.5
	680	293	195	2.12	35×55
	820	243	162	2.42	35×60
	1000	199	133	2.76	35×70
		199	133	2.85	40×60
	1200	166	111	3.32	35×80
		166	111	3.37	40×70
	1500	133	88	4	40×80
		133	88	4.15	45×75
	1800	111	74	4.85	40×100
		111	74	4.95	45×90
	2200	90	60	5.71	45×100
	450 (500) 2W	56	4739	2370	0.47
68		3903	1951	0.56	22×30
		3903	1951	0.56	25×25
82		3237	1618	0.64	22×35
100		2654	1327	0.7	22×40
		2654	1327	0.7	25×30
		2654	1327	0.7	30×25
120		2212	1106	0.73	22×45
		2212	1106	0.73	25×35
150		1769	885	0.8	22×50
		1769	885	0.82	25×40
		1769	885	0.83	30×30
		1769	885	0.86	35×25
180		1474	737	0.87	25×45
		1474	737	0.86	30×35
220		1206	603	0.94	25×50
		1206	603	0.95	30×40
		1206	603	0.91	35×30
270		983	492	1.11	30×45
		983	492	1.13	35×35
330	804	402	1.15	30×50	
	804	402	1.26	35×40	
390	681	340	1.31	35×45	
	565	282	1.5	35×50	
560	355	237	1.85	35×50	
680	293	195	2.20	35×60	
820	243	162	2.59	35×70	
1000	199	133	3.03	35×80	
	199	133	3.1	40×70	
1200	166	111	3.6	40×80	
	166	111	3.6	45×70	
1500	133	88	4.4	40×100	
	133	88	4.5	45×90	
1800	111	74	5.2	45×100	



CD 296 系列
Ratings for CD 296 Series

U _R (Surge Voltage) Code (V)	Rated Capacitance (μF)	Max ESR 20°C 120HZ (mΩ)	Typ ESR 20°C 120HZ (mΩ)	Rated Ripple Current 105°C/120HZ (Arms)	Size Φ DXL (mm)
500 (550) 2H	47	5647	2823	0.41	22×30
	56	4739	2370	0.47	22×30
	68	3903	1951	0.54	22×35
		3903	1951	0.54	25×30
	82	3237	1618	0.62	22×40
		3237	1618	0.62	25×35
	100	2654	1327	0.67	22×45
		2654	1327	0.67	25×40
		2654	1327	0.67	30×30
	120	2212	1106	0.77	22×50
		2212	1106	0.74	25×40
		2212	1106	0.77	30×35
		2212	1106	0.80	35×30
	150	1769	885	0.82	25×45
		1769	885	0.85	30×40
		1769	885	0.85	35×35
	180	1474	737	0.98	25×50
		1474	737	1.01	30×45
	220	1206	603	1.12	30×50
		1206	603	1.12	35×40
	270	983	492	1.25	30×50
		983	492	1.25	35×40
	330	804	402	1.36	35×45
	390	681	340	1.54	35×50
	470	565	282	1.69	35×60
		565	282	1.69	40×50
	560	355	156	2.25	35×65
		355	156	2.25	40×55
		355	156	2.25	45×50
	680	293	129	2.60	35×75
293		129	2.60	40×70	
293		129	2.60	45×55	
820	243	107	2.85	40×75	
	243	107	2.85	45×60	
1000	199	88	3.30	40×90	
	199	88	3.30	45×75	
1200	166	73	4.00	40×100	
	166	73	4.00	45×85	
	166	73	4.00	50×80	
1500	133	58	4.45	45×100	
	133	58	4.45	50×95	
1800	111	49	4.85	50×105	

寿命曲线 Lifetime Diagram

